

# TOWING & RECOVERY PRODUCTS



**WE DON'T JUST SELL THEM .....**  
**..... WE MAKE THEM !!!!!**

**WWW.ALL-LIFTS.COM**

**1(800)342-4188**

**PH: (518) 465-3461 FAX: (518) 465-0342**

# Winch Lines

**All-Lifts, Inc.** uses only top quality wire rope and hardware in the fabrication of its winch lines. All components are "**MADE in the USA**" from the best materials available.

End terminations are flemish eye mechanically spliced and swaged by experts in the manufacture of rigging and towing assemblies. All this is done to provide our customers with the safest and best products on the market. *When you buy from us, your buying quality!!*

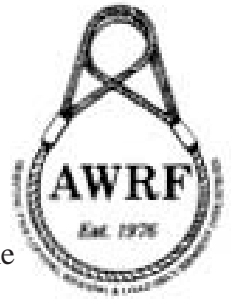

## 500 TON

### Hydraulic Swaging Machine



#### WIRE ROPE TYPE

The recommended type of wire rope utilized by All-Lifts in the fabrication of a winch line is:

#### 6X37C EIPS IWRC

- ✓ Constructed of 6 strands with between 31 and 37 wires/ strand for flexibility.
- ✓ Made with Extra Improved Plow Steel for added strength.
- ✓ IWRC steel core to resist crushing and flattening. (*unlike fibre core!!*)

### WIRE ROPE TYPES AVAILABLE:

6X19 IWRC	-Domestic or Import
6X37 IWRC	- Domestic or Import
6X19 FC	-Domestic or Import

#### QUESTIONS TO ASK WHEN PURCHASING WINCH LINES:

1. Is the wire rope used imported or domestic?
2. Is the wire rope IWRC or fibre core?
3. What grade wire rope is used?
4. What is the wire rope construction?
5. Are the hooks import or domestic?
6. What is the capacity of the hook used?
7. Is the splice return loop or flemish spliced?

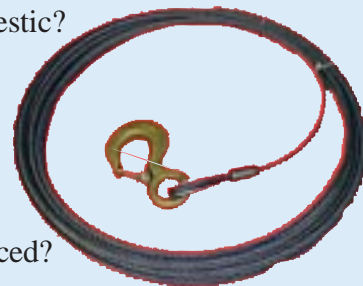

**ALL of these things effect the PRICE you pay and the QUALITY of the product you receive!**

*(Make sure your getting what you pay for.)*

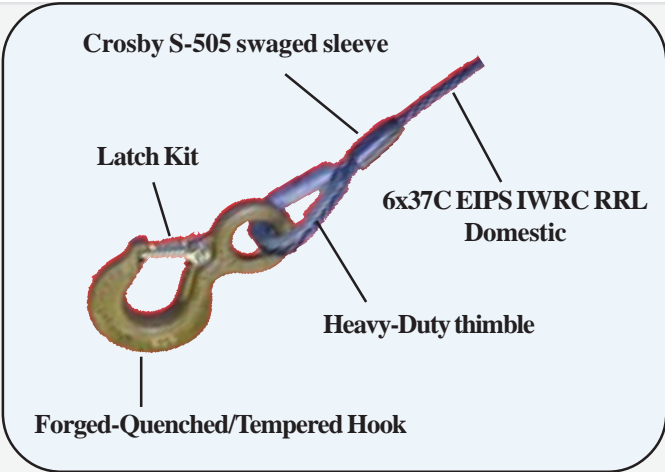

**WE DON'T JUST SELL WINCH LINES...  
 ... WE MAKE THEM !!!**

**6 X 37C IWRC**

PART#	SIZE	LENGTH
Y31H	3/8"	35
Y32H	3/8"	50
Y33H	3/8"	100
Y34H	3/8"	150
Y41H	7/16"	50
Y42H	7/16"	100
Y43H	7/16"	150
Y44H	7/16"	200
Y51H	1/2"	50
Y52H	1/2"	100
Y53H	1/2"	150
Y54H	1/2"	200
Y61H	5/8"	200
Y62H	5/8"	250
Y71H	3/4"	200
Y72H	3/4"	250

PART#	SIZE	LENGTH
Y31R	3/8"	35
Y32R	3/8"	50
Y33R	3/8"	100
Y34R	3/8"	150
Y41R	7/16"	50
Y42R	7/16"	100
Y43R	7/16"	150
Y44R	7/16"	200
Y51R	1/2"	50
Y52R	1/2"	100
Y53R	1/2"	150
Y54R	1/2"	200
Y61R	5/8"	200
Y62R	5/8"	250
Y71R	3/4"	200
Y72R	3/4"	250

**CUSTOM LENGTH CABLES ARE AVAILABLE  
 NO EXTRA CHARGE**

**SHEAVES:**

Sheaves are available in hundreds of size combinations. They are made from heavy duty steel and are supplied with a self-lubricating bronze bushing. Please use the diagram to determine which one fits your needs.

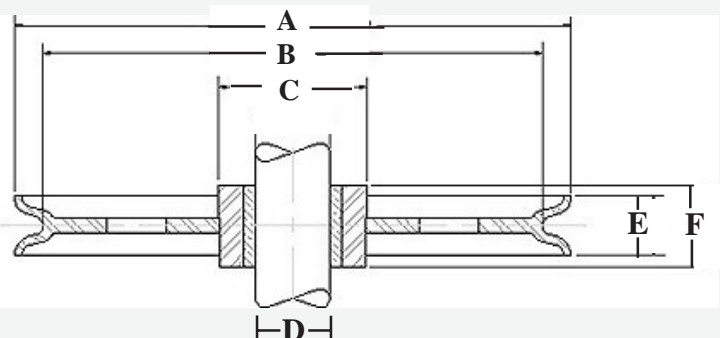

PART#	Capacity
EH-1	1 ton
EH-2	1.5-ton
EH-3	2-ton
EH-4	3-ton
EH-5	4.5-ton
EH-6	5-ton
EH-7	7.5-ton

**EYEHOOK (EH) / ROTATING HOOK (RH):**  
 Forged quenched and tempered hooks available in carbon or alloy steel makes these hooks the best on the market. The swivel action of the "RH" hook makes this style ideal for handling twisted winch lines and positioning the hook onto slings.

PART#	Capacity
RH-1	1 ton
RH-2	1.5-ton
RH-3	2-ton
RH-4	3-ton
RH-5	4.5-ton
RH-6	5-ton
RH-7	7.5-ton



EH

**Deformation Indicators:**

To check, measure the distance between the marks. The marks should measure in either an inch or half-inch increments. If the measurement does not meet this criteria, the hook throat opening has changed, thus indicating abuse or overload it should be inspected further for possible damage.

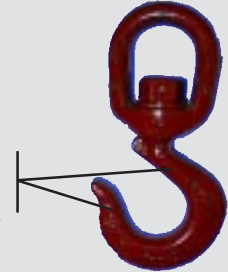

RH

**WIRE ROPE CLIP (WRC):**

Drop forged galvanized steel. Individually packaged with complete installation instructions. Made in USA.

Available sizes 1/8"-2-1/2" wire rope.

PART#	SIZE	# / end
WRC-1	3/8"	2
WRC-2	7/16"	2
WRC-3	1/2"	3
WRC-4	9/16"	3
WRC-5	5/8"	3
WRC-6	3/4"	4
WRC-7	7/8"	4



WRC

**ALWAYS SADDLE THE LIVE END !!!**



SADDLE

"LIVE"  
END**Latch Kits**

Latches come in a wide variety of brands and sizes. No two brands are exactly alike. Markings on the hook can help determine which brand and size you have. All-Lifts currently stocks Crosby, Campbell, and CM latch kits. Let our customer service reps help identify the proper latch you need. *Please call today!!!*



S4055



S4088



S4230

PART #	SIZE
CT-1	3/8"
CT-2	7/16"
CT-3	1/2"
CT-4	9/16"
CT-5	5/8"



CT

**COMBO CLAMP/THIMBLE (CT):**

Easy to install end termination great for attaching hooks or repairing winch lines in the field. Retains 70 to 75% of the wire rope breaking strength when properly installed.

**HEAVY THIMBLE (HT):**

Extra heavy duty thimble.  
 Hot Dip galvanized.  
 Available in sizes 1/8"-2-1/4".

PART #	SIZE
HT-1	3/8"
HT-2	7/16"
HT-3	1/2"
HT-4	5/8"
HT-5	3/4"



HT

# theCrosby<sup>®</sup>group, inc.

## "TERMINATOR" WEDGE SOCKET (TWS):

- ✓ Cast steel basket.
- ✓ Individually magnetic particle inspected.
- ✓ Easy to install in the field.
- ✓ Secures the tail of the wire rope to the wedge.
- ✓ Quic-Check system with "Go" / "No Go" holes to insure proper wire rope selection.
- ✓ 80% efficiency rating based on XXIP grade wire rope.
- ✓ Available in sizes from 3/8" - 1-1/8".

PART #	SIZE
TWS-1	3/8"
TWS-2	1/2"
TWS-3	5/8"
TWS-4	3/4"
TWS-5	7/8"



SBM

# theCrosby<sup>®</sup>group, inc.

## McKISSICK SNATCH BLOCK (SBM):

- ✓ Forged alloy heat treated hooks.
- ✓ Forged steel swivel tees, yokes and shackles.
- ✓ Quick release pin and drop side for easy installation.
- ✓ Available with self lubricating bronze bushing
- ✓ Made in the USA.

PART#	W.L.L.	SHEAVE	WR Size
SBM-1	2 ton	3"	5/16-3/8
SBM-2	4 ton	4-1/2"	3/8-1/2
SBM-3	8 ton	6"	5/8-3/4
SBM-4	8 ton	8"	5/8-3/4
SBM-5	12 ton	6"	3/4
SBM-6	12 ton	8"	3/4

# theCrosby<sup>®</sup>group, inc.



SPS

PART #	PART #	SIZE	W.L.L.
SPS-1	ABS-1	5/16"	1/2 ton
SPS-2	ABS-2	3/8"	1 ton
SPS-3	ABS-3	1/2"	2 ton
SPS-4	ABS-4	5/8"	3-1/4ton
SPS-5	ABS-5	3/4"	4-3/4ton
SPS-6	ABS-6	7/8"	6-1/2 ton
SPS-7	ABS-7	1"	8-1/2 ton



ABS

## Screw Pin (SPS) / Anchor Bolt (ABS):

Working Load Limit permanently shown on every shackle. Made from forged-quenched and tempered steel with alloy pins. Available in screw pin (SPS) or bolt pin w/nut and cotter pin (ABS).

# The Highest Quality Chain: **100% MADE IN USA**

## GR40



GRADE	SIZE	W.L.L.
GR 40	5/16"	3900
GR 40	3/8"	5400
GR 40	1/2"	9200

### HIGH TEST GRADE 40 (GR40)

- \*Carbon steel
- \*Self Colored finish
- \*Minimum ultimate load 3 times Working
- \*Permanently embossed with manufacturer and grade
- \*Not recommended for overhead lifting

## GR70



GRADE	SIZE	W.L.L.
GR 70	5/16"	5400
GR 70	3/8"	6600
GR 70	1/2"	11300

### TRANSPORT GRADE 70 (GR70)

- \*Carbon Steel
- \*Yellow chromate finish
- \*Excellent for tiedowns or towing. Best strength/cost value
- \*Permanently embossed with manufacturer and grade
- \*Not recommended for overhead lifting

## GR80



GRADE	SIZE	W.L.L.
GR 80	9/32"	3500
GR 80	3/8"	7100
GR 80	1/2"	12000
GR 80	5/8"	18100
GR 80	3/4"	24000

### ALLOY GRADE 80 (GR80)

- \*Carbon Steel
- \*Self colored finish
- \*Minimum ultimate load 4 times Working
- \*Permanently embossed with manufacturer and grade
- \*Certified for overhead lifting

### COUPLING LINK (HL):

Hammerlok style coupling link for use with GR80 chain. Made from alloy steel. Only requires a hammer for easy assembly. Made in USA

PART #	SIZE	W.L.L.
HL-1	9/32"	3500
HL-2	3/8"	7100
HL-3	1/2"	12000
HL-4	5/8"	18100



HL

### MISSING LINK (ML):

Forged steel quenched and tempered. Integral rivets join two halves. Justpeen rivets after making connection. Hot galvanized. Made in USA

PART #	SIZE	W.L.L.
ML-1	5/16"	1950
ML-2	3/8"	2750
ML-3	1/2"	4750
ML-4	5/8"	7250



ML

### TWIN CLEVIS (TCL):

Forged carbon steel body with alloy clevis pins for easy assembly. Ideal for use with GR30, GR40, GR70 chain. Made in USA.

PART #	SIZE	W.L.L.
TCL-1	1/4"-5/16"	4700
TCL-2	3/8"	6600
TCL-3	7/16"-1/2"	11250



TCL

### COLD SHUT (CS):

Quick and easy way to connect two pieces of chain. Available from 1/4"-5/8". Just bend closed and weld end.

PART #	SIZE	W.L.L.
CS-1	1/4"	750
CS-2	5/16"	1250
CS-3	3/8"	1900
CS-4	1/2"	3500



CS

**ALLOY GRAB HOOK (AGH):**

Heavy duty alloy cradle grab hook for use with GR80 chain. Cradle design supports entire link for ultimate safety. Made in USA by CM



AGH

PART #	SIZE	W.L.L.
AGH-1	9/32"	3500
AGH-2	3/8"	7100
AGH-3	1/2"	12000
AGH-4	5/8"	18100

**ALLOY SLIP HOOK (ASH):**

Heavy duty alloy slip hook for use with GR80 chain. Drilled for latch kit. Excellent for choking around load. Made in USA by CM



ASH

PART #	SIZE	W.L.L.
ASH-1	9/32"	3500
ASH-2	3/8"	7100
ASH-3	1/2"	12000
ASH-4	5/8"	18100

**CLEVIS GRAB HOOK (CGH):**

Forged alloy grab hook with clevis style pin for easy attachment. Can be used with GR80 chain.

Made in USA by Crosby



CGH

PART #	SIZE	W.L.L.
CGH-1	5/16"	4500
CGH-2	3/8"	7100
CGH-3	1/2"	12000
CGH-4	5/8"	15800

**CLEVIS SLIP HOOK (CSH):**

Forged alloy slip hook with clevis style pin for easy attachment. Can be used with GR70 chain.

Made in USA by Crosby



CSH

PART #	SIZE	W.L.L.
CSH-1	5/16"	4300
CSH-2	3/8"	5250
CSH-3	1/2"	9000
CSH-4	5/8"	13500

**OBLONG LINK (OL):**

Made from quenched and tempered forged alloy steel.

Individually proof loaded to 2 times rated capacity. Stock up to 2" diameter links.

Made in USA



OL

PART #	DIA.	W.L.L.
OL-1	1/2"	4920
OL-2	5/8"	6600
OL-3	3/4"	10320
OL-4	1"	24360

**CSH-C**

*Drilled for latch kit installation*



**CLEVIS SLIP HOOK (CSH-C):**

Forged alloy slip hook with clevis style pin for easy attachment. For use with GR80 chain.

Made in USA by Campbell Chain

PART #	SIZE	W.L.L.	Latch #
CSH-C1	1/4"	4100	#22
CSH-C2	5/16"	5100	#23
CSH-C3	3/8"	7100	#25

**The Ultimate Control Grab Hook**

LG80



PART#	SIZE	W.L.L.
LG80-1	1/4"-5/16"	3500
LG80-2	3/8"	7100
LG80-3	1/2"	12000
LG80-4	5/8"	18100

**LOCKING GRAB HOOK (LG80)**

This uniquely designed grab hook solves the problem of chain falling out of the hook. With its patented spring loaded pin system, the chain is kept in place. Pull the pin back for quick release and the chain link is easily removed. Made alloy steel for use with GR80 chain, it is ideal for towing, recovery, or safety chains.

Made in Germany by KWS. (Replacement pins in stock)

**LEVER BINDER (LB)**

- \*Extra heavy construction at leverage point
- \*Forged steel, Quenched and tempered
- \*Ball and socket swivel at hook assemblies.
- \*Made in USA

PART#	SIZE	W.L.L..
<b>LB-1</b>	5/16"-3/8"	6600
<b>LB-2</b>	3/8"-1/2"	9200
<b>LB-3</b>	1/2"-5/8"	13000



**LB**

**RACHET BINDER (RB)**

- \*Continuous take-up, infinite adjustment
- \*Ratchet spring rust proofed
- \*All load bearing or holding parts forged
- \*Easy operating positive ratchet
- \*Made in USA

PART#	SIZE	W.L.L..
<b>RB-1</b>	5/16"-3/8"	6600
<b>RB-2</b>	3/8"-1/2"	9200
<b>RB-3</b>	1/2"-5/8"	13000



**RB**

**TIEDOWN CHAINS(LS1 AND LS2)**

- \*Carbon steel
- \*Yellow chromate finish to resist rust
- \*Available in 5/16" or 3/8" chain diameter
- \*GR70 Transport chain
- \*Standard length 20' long
- \*Stamped w/ chain grade and manufacturer

PART #	SIZE	W.L.L..
<b>LS1</b>	5/16 x 20'	5400 lbs.
<b>LS2</b>	3/8 x 20'	6600 lbs



**TOW CHAINS**

Available in **GR 70 (Transport)** sizes 5/16" to 1/2" and **GR 80 (Alloy)** sizes 9/32" to 3/4". **All** tow chains are supplied with alloy hooks attached to each end with clevis pins. 100% Made in the USA.

**Grade 70 (Transport)**

PART #	SIZE	LENGTH
<b>TC17</b>	5/16	10'
<b>TC27</b>	5/16	12'
<b>TC37</b>	5/16	15'
<b>TC47</b>	3/8	10'
<b>TC57</b>	3/8	12'
<b>TC67</b>	3/8	15'
<b>TC77</b>	1/2	10'
<b>TC87</b>	1/2	12'
<b>TC97</b>	1/2	15'

**Grade 80 (Alloy)**

PART #	SIZE	LENGTH
<b>TC18</b>	3/8	10'
<b>TC28</b>	3/8	12'
<b>TC38</b>	3/8	15'
<b>TC48</b>	1/2	10'
<b>TC58</b>	1/2	12'
<b>TC68</b>	1/2	15'
<b>TC78</b>	5/8	10'
<b>TC88</b>	5/8	12'
<b>TC98</b>	5/8	15'



Because all chain and hardware is assembled by All-Lifts, any length can be ordered at no extra charge w/same day shipping.



**GL10**



PART#	SIZE	W.L.L..
<b>GL-10</b>	9/32	3500
<b>GL-11</b>	3/8	7100
<b>GL-12</b>	1/2	12000
<b>GL-13</b>	5/8	18000

**GRAB LINK(GL10)**

This drop forged alloy link is perfect for creating your own tow chain in the field quickly and efficiently. For use with GR80 chain. Sizes from 9/32"-5/8". Made in the USA.

**PEAR LINK W/ GRAB HOOKS (TH-1)**

Made for use with 5/16" GR70 chain, this unit is great for V-chain configurations. 5400lbs. working load limit. Made in USA.

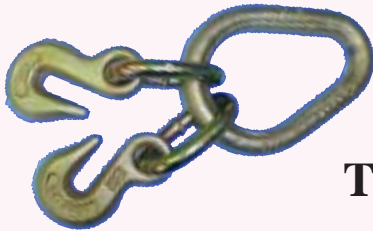

**TH-1**

**MINI-J W/RING (MJR)**

This Mini-J hook comes with a large ring attached for easy connection to any chain or strap. Yellow chromate plated to resist corrosion.

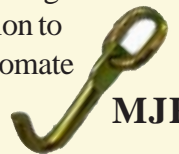

**MJR**

**RTJ CLUSTER(RTJ):**

A must in the auto transport industry, this cluster contains the standard T-hook, R-hook, and 5/8" mini J-hook. All coated in a bright yellow chromate finish and connected to 2 large welded rings for easy connection to any custom strap assembly. (Customized clusters are available w/ R-hook, T-hook, mini J-hook, grab hook, or extra links in any combination).

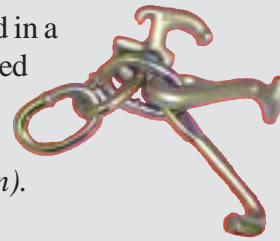

**RTJ**

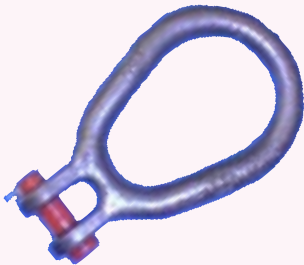

PART #	SIZE	W.L.L.
<b>CL-1</b>	5/16"	4400
<b>CL-2</b>	3/8"	6600

**CLEVIS LINK (CL):**

Drop forged from bar quality steel. Heat treated for greater strength. Clear protective finish to resist rust. *Not for overhead lifting.*

**Towing hardware of the highest quality  
 GR70 R-hooks, T-grabs, T-hooks, mini J's,  
 Long J hooks, etc.etc.etc**

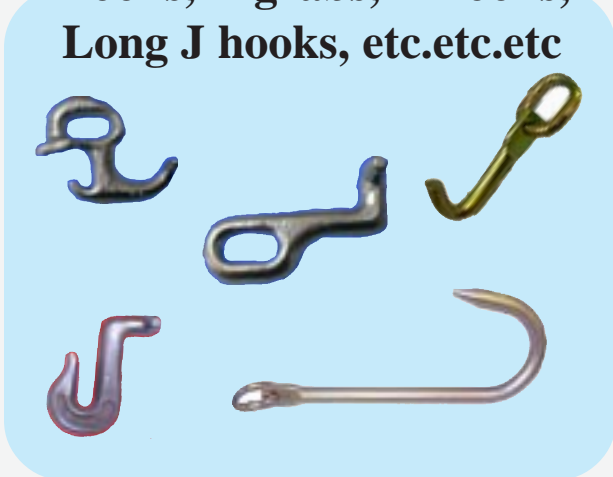

# RECOVERY STRAPS

Made from resin treated 9800lb. nylon webbing. Eyes are folded to make them easier to use with eyehooks or web shackles. Both eyes and edges are lined with cordura webbing for durability and resistance to wear. Each sling is individually tagged with the rated capacity, and serial number. **All** recovery straps are manufactured at our plant in Albany, NY. A wide range of lifting strap sizes are available from 1"-12" width, 1-4 ply and any length.

## CORDURA REINFORCED EYES AND EDGES

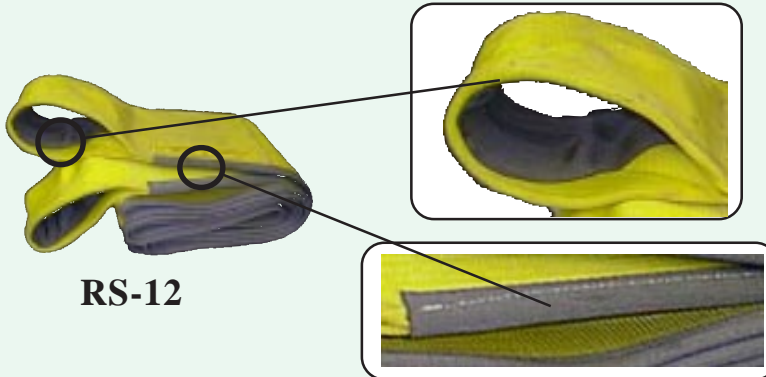

RS-12

PART #	WIDTH	LENGTH
RS-616	6	16
RS-620	6	20
RS-626	6	26
RS-816	8	16
RS-820	8	20
RS-826	8	26
RS-1216	12	16
RS-1220	12	20
RS-1226	12	26



WS

### WEB SHACKLE (WS):

Heat treated carbon steel body. Alloy heat treated steel pins. Hot Dip Galvanized for corrosion resistance. Helps reduce wear on the recovery strap eyes. Sizes from 2"-6"

PART#	SIZE	W.L.L.
WS-2	2"	8050 lbs.
WS-3	3"	10800 lbs.
WS-4	4"	13050 lbs.
WS-5	5"	18000 lbs.
WS-6	6"	24000 lbs.

## the Crosby group, inc. / Sling Saver Shackle

S-280



- ✓ Alloy steel construction.
- ✓ Easy connection to synthetic straps and round slings.
- ✓ Polymer spool to protect and center eye
- ✓ 5 to 1 safety factor

PART#	WEB WIDTH	W.L.L.
S280-A	2"	3-1/4 ton
S280-B	3"	4-1/2 ton
S280-C	4"	6-1/4 ton
S280-D	6"	8-1/2 ton



TO AVOID THIS:

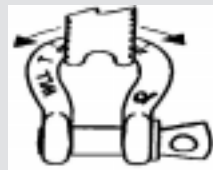

USE THESE



# V-SLINGS

## V-CHAINS

### LONG "J" V-CHAIN (VC-1)

V-Chain 5/16" x 2'  
 w/extra long "J" hooks  
 Adjustable grab hooks

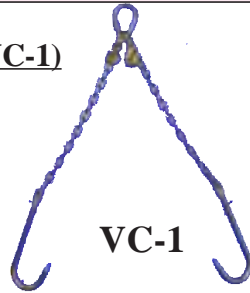

**VC-1**

### SPORTS V-CHAIN (VC-2)

V-Chain 5/16" x 2'  
 w/ short "J" hooks  
 Adjustable grab hooks

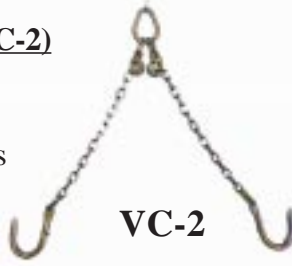

**VC-2**

### COMBO V-CHAIN (VC-3)

V-Chain 5/16" x 2'  
 w/ short "J" hooks and T-hook  
 Adjustable grab hooks

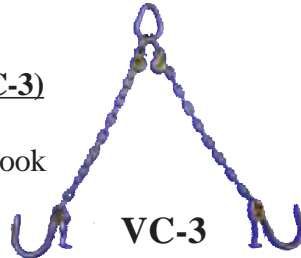

**VC-3**

### CLUSTER V-CHAIN (VC-4)

V-Chain 5/16" x 3'  
 w/ RTJ cluster hook  
 Adjustable grab hooks

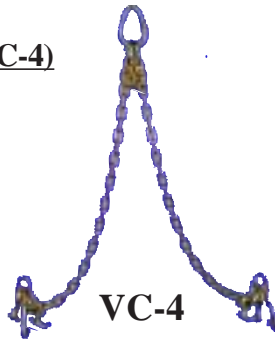

**VC-4**

## V-STRAPS

### LONG J V-STRAP (VS-1)

3" wide polyester web  
 2 ply construction  
 24" w/ long "J" hooks  
 5/8" forged pear link

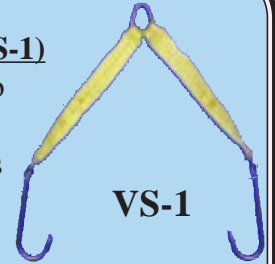

**VS-1**

### V-STRAP (VS-2)

3" wide polyester web  
 2 ply construction  
 24" legs w/ short "J" hooks  
 5/8" forged pear link

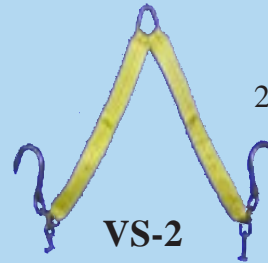

**VS-2**

**VS-3S: 24" legs**

**VS-3L: 36" legs**

### COMBO V-STRAP (VS-3)

3" wide polyester web  
 2 ply construction  
 w/ short "J" hooks and T hooks  
 5/8" forged pear link



**VS-3**

### CLUSTER V-STRAP (VS-4)

3" wide polyester web  
 2 ply construction  
 30" legs w/ RTJ cluster  
 5/8" forged pear link

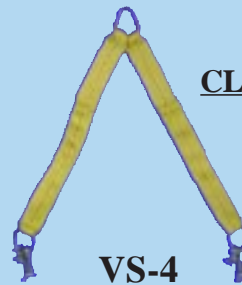

**VS-4**

**\*\*\* ALL V-SLINGS ARE NOW STOCKED IN GRADE 70 \*\*\***

# LOAD SECURITY SYSTEMS

**TD-1****TRUCK TIEDOWN STRAP (TD-1)**

Rugged 2" x 27' tiedown strap.

10,000 lbs. breaking strength.

3,300 lbs working load limit.

Flat hooks on both ends.

Long wide handle ratchet standard.

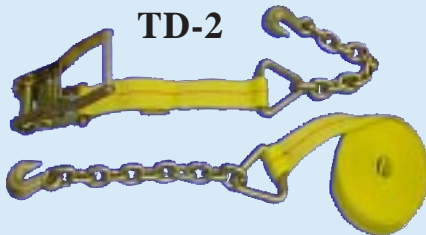
**TD-2****TRUCK TIEDOWN STRAP (TD-2)**

Same as TD-1 w/ GR70 chain extensions



## X-Series - CAR CARRIER AND FLAT BED COMPONENTS

**Ratchet w/Snap Hook XR-1**

Standard 2" ratchet with snap hook.

5000lb. W.L.L.

**Ratchet w/Chain Extension XR-2**

Standard 2" ratchet with 12" of 5/16"

GR70 chain attached. 5000lb. W.L.L.

**Strap w/ Snap Hook XS-1**

2" polyester tiedown strap x 6' length w/ snap

hook attached on one end 5000lb. W.L.L.

**Strap w/ RTJ Cluster XS-2**

2" polyester tiedown strap 6' length

with RTJ cluster attached on one

end. 5000lb. W.L.L.

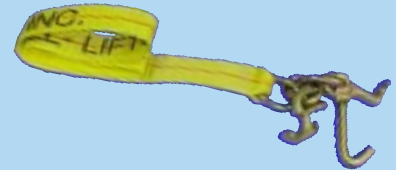
**Cargo Strap w/ Flat Hook (R430-FH)**

4" x 30' replacement strap for use with weld-on, portable and sliding strap winches. Made with rugged polyester fabric to resist stretching. Comes with flat hook that easily fits over rub rails.

This strap has a 5000lb. W.L.L. and 15,000 breaking strength.

*(Custom lengths available with no extra charge or delay.)*

**R430-FH****Cargo Strap w/ Delta Ring (R430-DR)**

4" x 30' replacement strap. Made with rugged polyester. Comes with forged steel delta ring that will fit a 2-1/2" diameter pin. This strap has a

5000lb. W.L.L. and 15,000 breaking strength. *(Custom lengths available*

*at with no extra charge or delay)*

**R430-DR****Cargo Winches**

Heavy duty steel cargo winches designed for use on flat bed trailers. They come in several styles including weld-on, portable, and sliding. All winches are designed to meet the requirements of DOT and CHP. For use with 3" and 4" cargo straps, they have a 5000lb. W.L.L. and come with a red oxide painted finish.



**AXS**

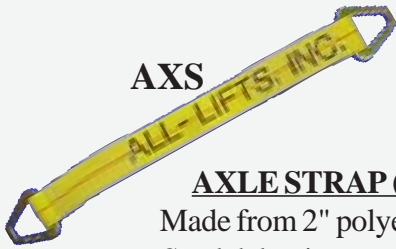

**AXLE STRAP (AXS)**

Made from 2" polyester web  
 Steel delta rings on each end  
 10,000 lbs. breaking strength  
 22" standard length

**Tiedown w/ Snap Hooks XTD-S**

This 2" x 6' tiedown is equipped with snap hooks for attachment to any D-ring configuration. Excellent for use with the AS-1 axle strap during vehicle transport, each hook has a spring loaded latch for secure attachment. 5000lb. W.L.L.



**XT-S**

**Underlift Tiedown (UTD-1)**

For use with an under reach style tow truck. To secure the vehicle being transported, simply wrap the strap around the axle and encircle each fork.



Straps are designed to be used in pairs. They are constructed of 2" polyester resin treated tiedown web, standard ratchet and narrow flat hook. Each strap is permanently attached to each ratchet. Once installed on the towed vehicle, the straps have a combined breaking strength of 20,000 lbs !! Can be used with rubber wear pads (*RWP23*) to extend strap life.

**Tiedown w/ Snap Hook & RTJ Cluster XT-CL**

This 2" x 8' tiedown is equipped with snap hook on the dead end and an RTJ Cluster on the adjustment end. A must for use during vehicle transport, the snap hook has a spring loaded latch and the cluster provides multiple ways to easily secure any car. 5000lb. W.L.L.



**XT-CL**

**Tiedown w/ XMS-2 Ratchet & RTJ Cluster XT-CH**

This 2" x 8' tiedown is equipped with RTJ Cluster like the XTD-SCL but the ratchet has a 5/16", GR70, 12" chain attached that easily fits in keyhole deck slots. A favorite for vehicle transport, the RTJ cluster provides multiple ways to easily secure any car. 5000lb. W.L.L.



**XT-CH**

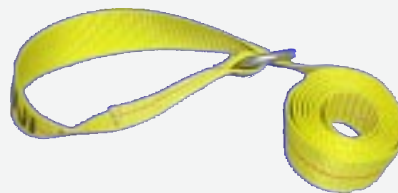

















**LASSO-2:** 2" X 8' Polyester. Rated 5000lbs.

All-Lifts, Inc. is a manufacturer of synthetic slings and tiedowns. This gives All-Lifts the flexibility to fabricate a wide variety of custom products for any application.



## Available Hardware:

### TIEDOWN FITTINGS

	Part #		Part #
	SNH-1		R-2
	SHK-1		WHK-2
	WDR-2		GHK-2
	FDR-2		SNH-2
	FH-2		FH-3/4
	TSH-2		CE
	SH-2		RTJ
	NFH-2		MJR
	DR-3/4		

### RATCHETS

	810
	800
	802
	803
	806
	808

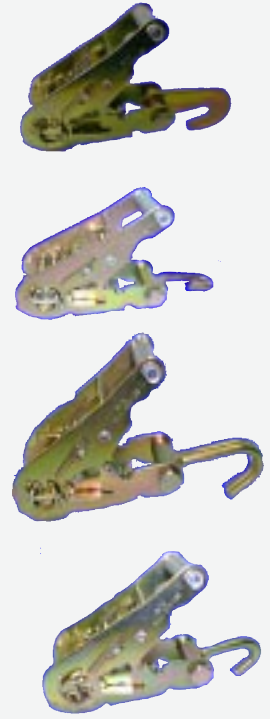

# SLING PROTECTION

One of the most common causes for strap failure is the use of a sling or tiedown that has been damaged from sharp edges or other wear points. Sling protectors are designed to protect both the strap and the load. Avoid costly damage to tiedowns or lifting straps. Sling protectors allow for strap to adjust without scrubbing against the load. They are easy to use and will prolong the life of any strap.

Wear protection material can be permanently fixed to any lifting strap or tiedown. The most common areas for this type of protection includes the eyes, faces or edges of the sling. Below are examples of the types of wear protection available.



## CORDURA SLEEVES (CS)

Made of durable cordura material  
Available in 2"-6" widths

**TWP-1:** Tube style nylon wear pad slides on for easy use. Available for straps 1"-12" wide. Sold by the foot and available in any length. Not only great for use with straps but can also be used with chain.

**PWP-4:** Polymer corner protector slides onto cargo straps up to 4" wide. Can be used with chain. Excellent protection against sharp edges.

**RWP23:** 3/16" thick rubber wear pad fits 2"-3" straps.

**RWP4:** 3/16" thick rubber wear pad fits 4" straps.



**RWP23**



Although this is the first catalogue All-Lifts, Inc has printed exclusively for the towing and recovery industry, we have over 30 years of experience manufacturing and selling these products.

Over the years, All-Lifts has developed a reputation of supplying the best in quality and service. We strive to be experts on the products we sell and we try to help our customers use this product knowledge to effectively and safely get the job done.

We welcome any questions or advice on how we can better serve the towing / recovery industry and we look forward to hearing from you.

Call 1-800-342-4188 and let us know how we are doing !!!!



**WIRE ROPE**  
**WINCH LINES**  
**SHEAVES**  
**EYEHOOKS**  
**LATCH KITS**  
**THIMBLES**  
**WEDGE SOCKETS**  
**SNATCH BLOCKS**  
**SHACKLES**  
**CHAIN**  
**GRAB HOOKS**  
**SLIP HOOKS**  
**TOW CHAINS**  
**TIEDOWNS**  
**CHAIN BINDERS**  
**CLUSTER HOOKS**  
**GRAB LINKS**  
**RECOVERY STRAPS**  
**WEB SHACKLES**  
**V-SLINGS**  
**RATCHET STRAPS**  
**TIEDOWN STRAPS**  
**SLING PROTECTION**

**1(800)342-4188**

**WWW.ALL-LIFTS.COM**